

charnwood

Woodworking machinery at its best!

12" BANDSAW OPERATING INSTRUCTIONS MODEL: W721



CE

Charnwood, Cedar Court, Walker Road,
Bardon, Leicestershire, LE67 1TU

Tel. 01530 516 926 Fax. 01530 516 929

email; sales@charnwood.net website; www.charnwood.net

GENERAL SAFETY RULES



WARNING: Do not attempt to operate the machine until you have thoroughly read and understood completely all instructions, rules, etc. contained in this manual. Failure to comply may result in accidents involving fire, electric shock, or serious personal injury. Keep this owner's manual and review frequently for continuous safe operation.

1. Know your machine. For your own safety, read the owner's manual carefully. Learn its application and limitations, as well as specific potential hazards pertinent to this machine.
2. Make sure all tools are properly earthed.
3. Keep guards in place and in working order. If a guard must be removed for maintenance or cleaning, make sure it is properly replaced before using the machine again.
4. Remove adjusting keys and spanners. Form a habit of checking to see that the keys and adjusting spanners are removed from the machine before switched it on.
5. Keep your work area clean. Cluttered areas and workbenches increase the chance of an accident.'
6. Do not use in dangerous environments. Do not use power tools in damp or wet locations, or expose them to rain. Keep work areas well illuminated.
7. Keep children away. All visitors should be kept a safe distance
8. from the work area.
9. Make workshop childproof. Use padlocks, master switches and remove starter keys.
10. Do not force the machine. It will do the job better and be safer at the rate for which it is designed.
11. Use the right tools. Do not force the machine or attachments to do a job for which they are not designed. Contact the manufacturer or distributor if there is any question about the machine's suitability for a particular task.
12. Wear proper apparel. Avoid loose clothing, gloves, ties, rings, bracelets, and jewellery which could get caught in moving parts. Non-slip footwear is recommended. Wear protective hair covering to contain long hair.
13. Always use safety glasses. Normal spectacles only have impact resistant lenses. They are not safety glasses.
14. Do not over-reach. Keep proper footing and balance at all times.
15. Maintain the machine in good condition. Keep the machine clean for best and safest performance. Follow instructions for lubrication and changing accessories.
16. Disconnect the machine from power source before servicing and when changing the blade.

17. Never leave the machine running unattended. Turn the power off. Do not leave the machine until it comes to a complete stop.
18. Do not use any power tools while under the effects of drugs, alcohol or medication.
19. Always wear a face or dust mask if operation creates a lot of dust and/or chips. Always operate the tool in a well ventilated area and provide for proper dust removal. Use a suitable dust extractor.

ADDITIONAL RULES FOR BAND SAWS

1. Ensure that the saw table is clear of off-cuts, tools or anything else that might foul the work-piece.
2. When cutting long boards use one or more roller stand(s) to support the work or have a competent helper to support it as it feeds off the rear of the table.
3. Always make sure that the blade is tracked and tensioned correctly before starting to use the saw.
4. Always use a brush to clear the table of dust or debris. **NEVER** use your hands, especially when the machine is running.
5. Always ensure that the thrust bearings and guide blocks are correctly adjusted before using the saw.
6. ALWAYS USE A PUSH STICK WHEN IT IS NECESSARY TO PUSH ANY PIECE OF MATERIAL OF SUCH SIZE THAT IT WOULD BRING YOUR HANDS WITHIN 30 CM OF THE BLADE.
7. Do not cut material that is badly warped or which has screws or nails in it.
8. Be extra vigilant when cutting stock which has loose knots in it as these may fly out of the saw.
9. NEVER tilt the table when the saw is running.
10. To avoid exposure to hazardous dust, do not use this saw without connecting it to a suitable dust extractor.
11. Always work with a sharp saw blade and feed the work at a rate suited to the thickness and hardness of the material.

Note: This band saw has been designed and built solely as a woodworking machine. Do not modify it in any way or use it for anything other than its designated purpose. Neither the manufacturer nor the supplier are liable for any damage or injury caused by incorrect assembly, operation or electrical connection of this machine.

Specification

Table size	550 x 400 mm
Table height	1090 mm
Motor	750W
Blade length	2240 mm
Blade widths	6 to 19 mm
Blade speeds (no load)	360 and 720 m/min
Blade widths	6 to 12 mm
Maximum depth of cut at 90°	160 mm
Maximum depth of stock at 45°	89.4 mm
Throat capacity	305 mm
Dust extractor hose connection	100 mm
Weight	73kg nett
Dimensions (W x D x H)	800 x 630 x 1720 mm

Features

Precision ground, cast iron table with adjustable scale on rip fence carrier

0 to 45° table tilt

High Quality, British made blade

High blade speed for cutting most wood

Low blade speed for cutting very hard woods, plastic and metal (with a suitable blade)

Easily portable machine

Quick release, positive lock rip fence

Cross cut/mitre fence with easily read scale

Tool free blade tracking and tensioning

Unpacking



Cut the strapping, open the carton and remove all parts from the packaging

Assembly

Building the stand This is most easily accomplished on a bench or table

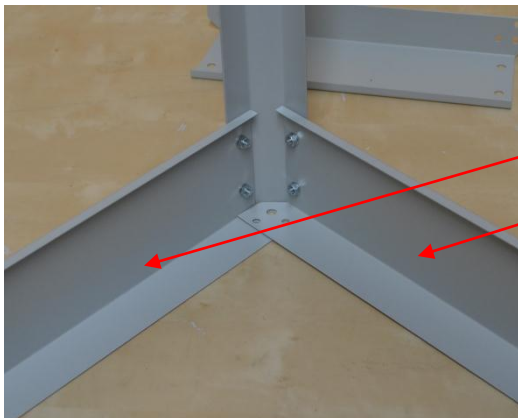

Leave all nuts and bolts finger tight until you have finished assembling this stand. Start with the long top rail and bolt it inside one leg.

Add a short rail, making sure that it sits above the long rail as viewed from the underside, i.e. as you have it on the bench.

Continue until all four legs and rails are joined.

Add the lower rails and feet.

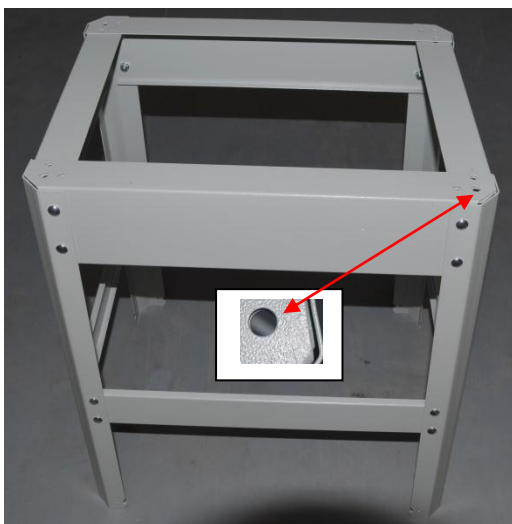

Carefully align the parts until the stand is square and ensure that the 4 large holes in the top corners are lined up as you will need to put bolts through these to fix the saw to the base.

Fitting the Saw to the Stand



If you have someone to help you, the easiest way to join the saw and the stand is to lift the saw and lower it into place. Secure it with the four countersunk setscrews, washers and nuts provided.

Fixing bolts

Alternately;
If you have nobody to help, lower the saw onto its back and bolt the stand to it. After tightening the fixing bolts, lift the top of the saw and pivot it on the rear feet until it is upright and all four feet are on the ground.

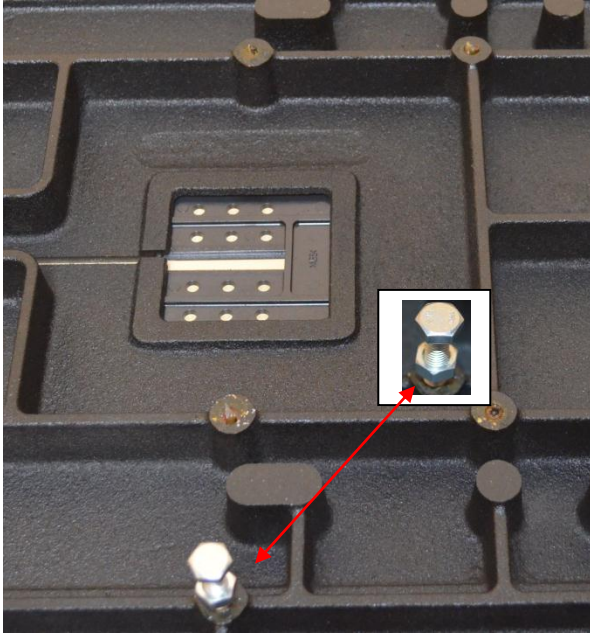

Screw the longest of the 6 mm hex headed bolts into its hole as shown.

Place the table in position on the trunnion and fix it with the four remaining 6 mm bolts.

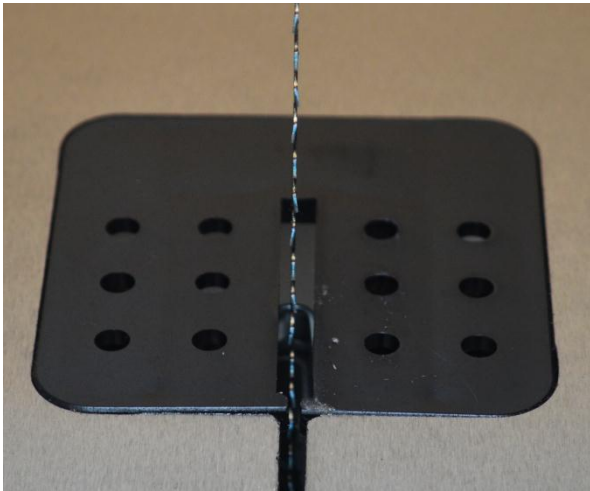

Check to see if the blade is centred in the slot. You will probably find that it is offset to one side or the other.

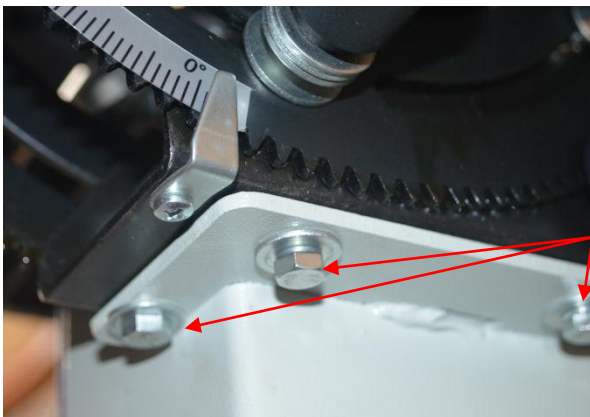

This pointer is adjustable if the setscrew is loosened. You may need to make a small adjustment after the table is set perpendicular to the blade.

If the table needs to be moved laterally to centre the slot on the blade, loosen these three screws, move the table to the correct position and retighten the bolts.

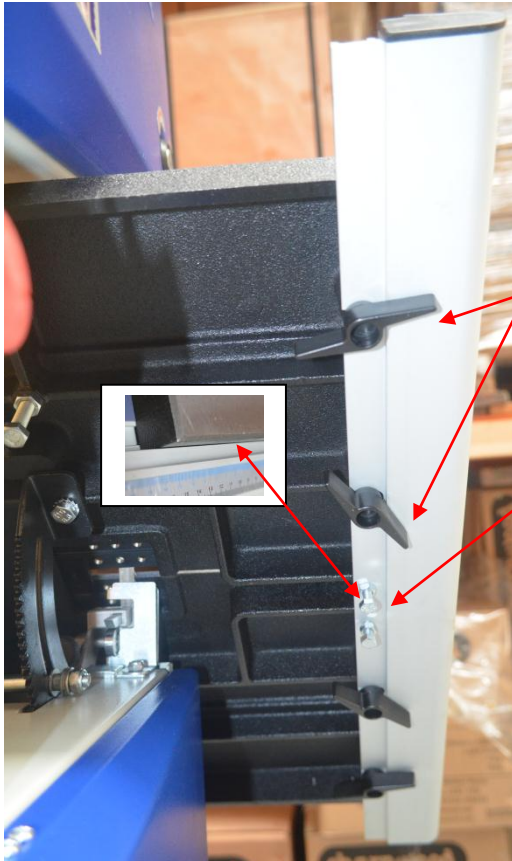

Screw the four hex, wing bolts and washers into the tapped holes on the underside of the table and slide the rip fence carrier on to them.

Adjust the two hex headed bolts so that the carrier fits snugly to the table with no gap between its upper edge and the table.

If you do not keep the carrier tight to the table the rip fence will not be perpendicular to it.



Screw in and lock the push stick hanger.

Hang the push stick on it and remember that this is one of the world's best finger preservers!



Locate the tension adjustment knob and using a suitable tool, remove the cap. Be careful not to lose the nut which is inside.

Place it over the spindle sticking out of the top of the saw, screw on the nut and lock the knob between the two nuts.

Replace the cap.

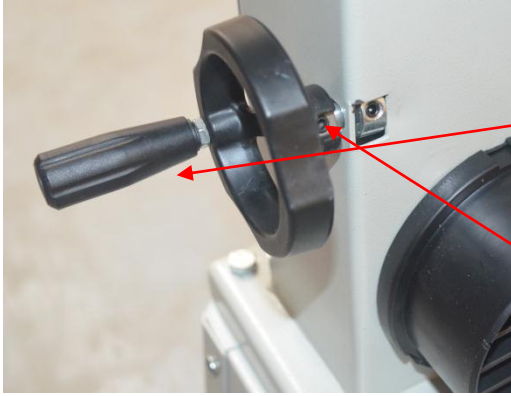

Fit the control handle to the spindle protruding from the side of the saw. Rotate the handle, so that the grub screw tightens onto the flat side on the spindle.

Tighten the grub screw securely.

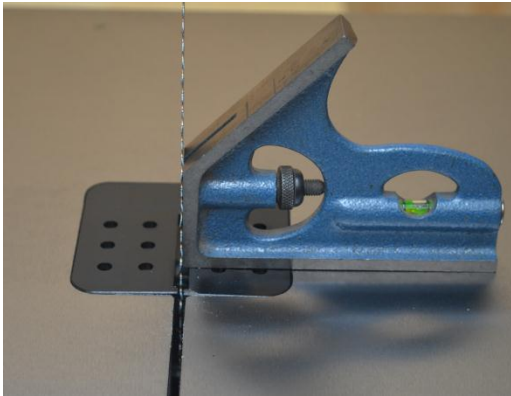

Apply a little tension to the blade and use a set square to position the table at right angles to it.

Lock it in position and if necessary, adjust the level stop screw and the pointer so that it aligns with the zero as shown earlier.

Setting up your saw



Quick blade tensioner (shown in tight position). Looking from the front of saw, turn the lever anticlockwise to slacken the tension.

Blade guard positioner and lock

Tracking control and lock



After ensuring that the quick tension lever is set in the tensioned position, adjust the blade tension with the hand wheel on top of the upper housing.

'Pluck' the back of the blade, as you would the string of a double bass, at this point. As the blade tension is increased, the pitch of the sound will rise. Stop increasing the tension as soon as the sound starts to become dull. Alternatively, raise the blade guard to its highest position and adjust tension until the blade, at the midpoint between table and guard can be deflected only 3 to 5 mm with finger pressure.

Turn the upper wheel clockwise, by hand and adjust the tracking control until the blade is centred on the wheel, as shown in the inset illustration. Lock the adjuster in this position.

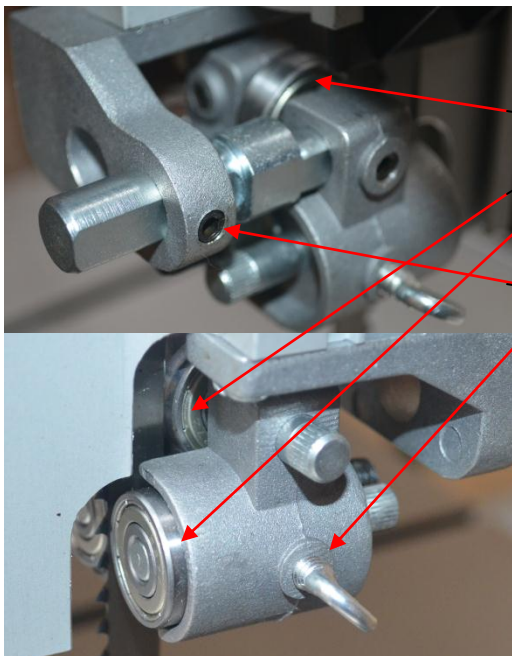

The upper and lower thrust and guide bearings should be set up next.

Thrust bearing

Guide bearing

Guide bearing locking screws

Thrust bearing locking screw

The thrust bearing should be about 0.5 mm behind the back of the blade. Adjust it and lock it place.

Slacken the guide bearing locking screws, move the bearings in until they touch the blade. Rotate the top wheel by hand a few turns and lock the bearings in place.

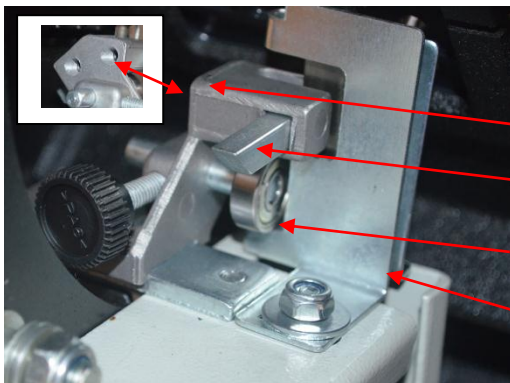

The lower thrust bearing and guide pins are adjusted similarly.

Guide pin locking screw (on rear face)

Guide pin

Lower thrust bearing

Blade guard

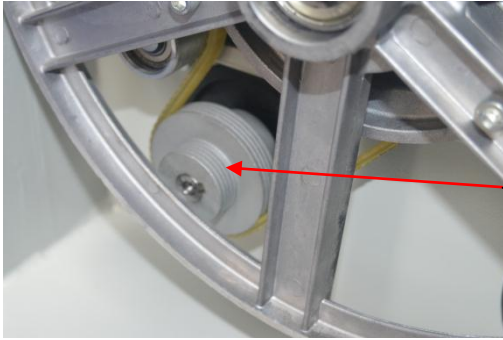

Release the belt tension by turning the tension control handle on the front of the lower housing. Move the belt from the larger pulley to the smaller one and then from the smaller to the larger on the other pair. Always have the drive belt on one large and one small pulley.

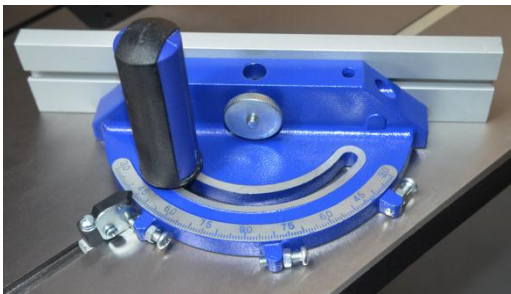

This bandsaw is equipped with a cross cut/mitre fence which can be fitted as shown.

The fence is equipped with adjustable stops for 45° and 90° cuts.



The rip fence is reversible and may be used on either side of the blade.

Your bandsaw is now ready for use but it is recommended that a suitable dust extractor is connected before use.

Changing the Blade

Bandsaw blades are sharp enough to cause injury even when too blunt to cut wood! It is recommended that protective gloves be worn when handling blades.

Unplug the bandsaw from the mains socket, slacken off the blade tension and open the upper and lower housing doors.

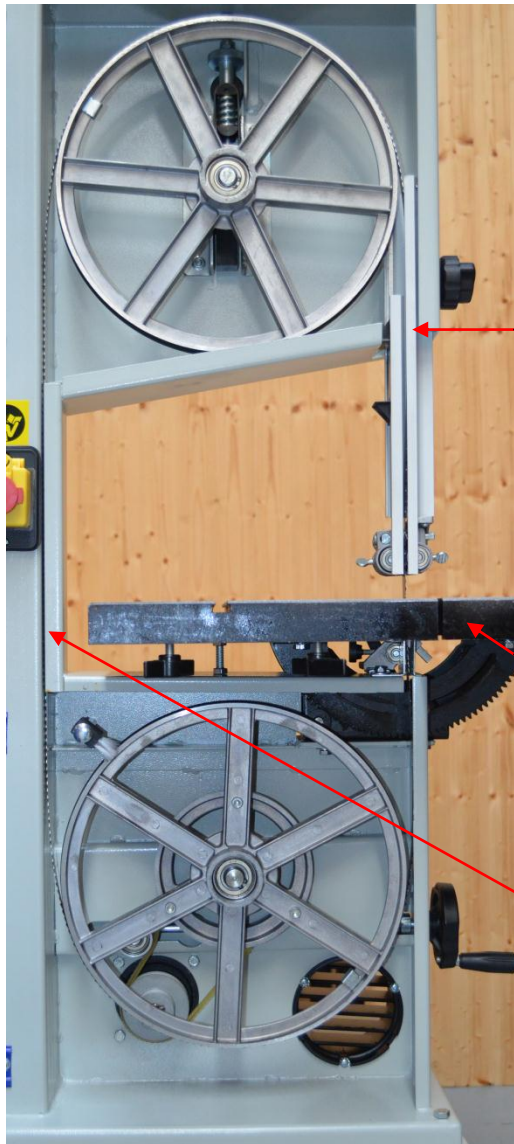

Lower the blade guard

Remove the rip fence carrier

Slide the blade off upper and lower wheels, bringing it out of the machine via the slots in the rear frame and the blade guard.

Reverse these steps to fit the new blade. Ensure that the teeth are at the front and pointing down.

Position the blade between the guide bearings and pins. Tension and adjust the tracking as done during the initial set up. Check and adjust, if necessary, the position of the bearings and the guide pins.

W721 EXPLODED DIAGRAM

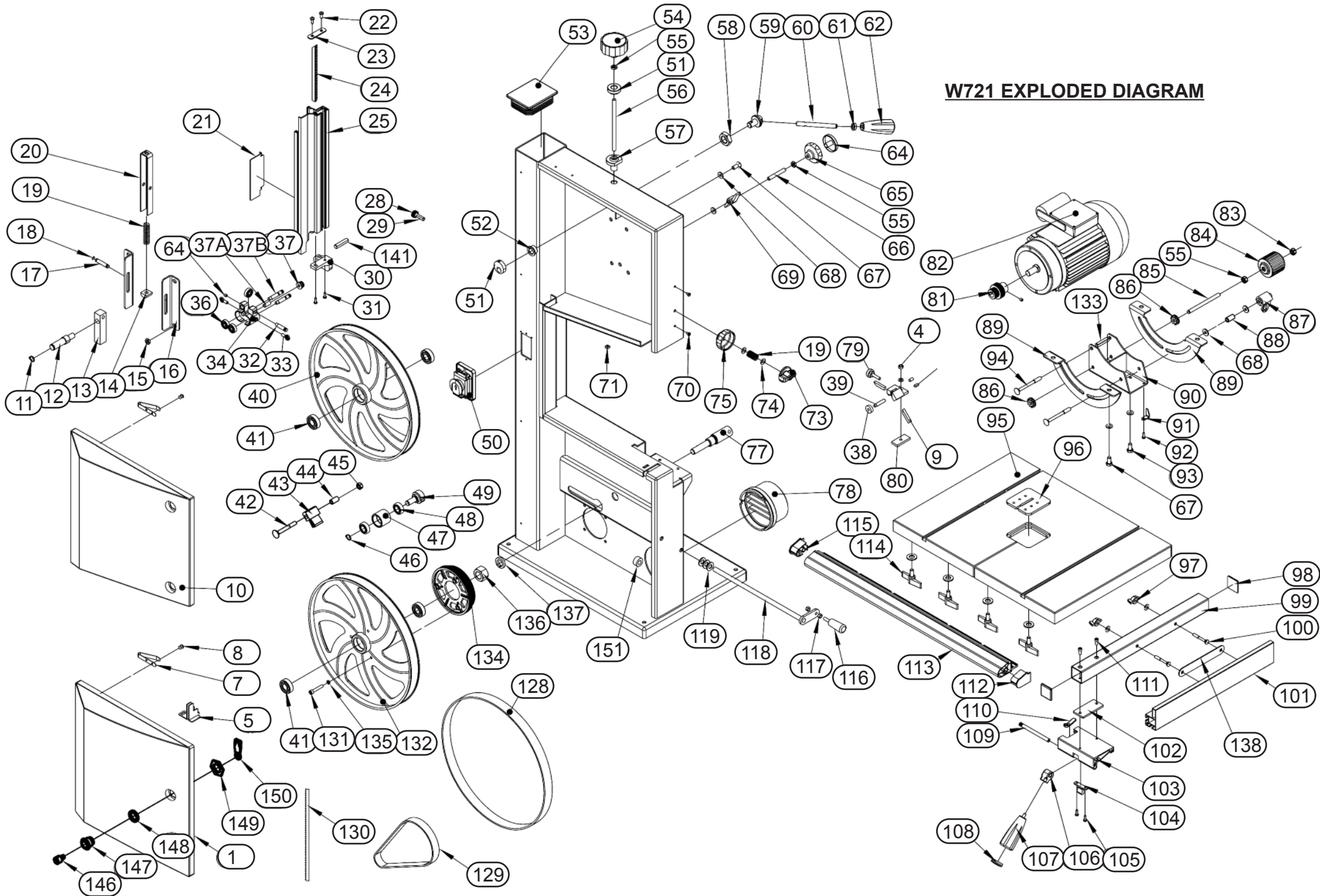

W721 Parts List

001 Lower door	002 Cap head bolt
003 Spacer bush	004 Lock nut
005 n/a	006 Pilot guide
007 Spring plate	008 Rivet
009 Pilot Pin	010 Upper door
011 Circlip	012 Upper bearing bolt
013 Upper bearing bolt support	014 Nut
015 Hex. flanged nut	016 Guide plate
017 Shaft	018 Split washer
019 Spring	020 Tension bracket frame
021 Slider	022 Self tapping screw
023 Cover board	024 Rack
025 Guide carrier extrusion	026 Plastic guide
027 n/a	028 Pinion
029 Pinion shaft	030 Bottom cap
031 Self tapping screw	032 Cap head screw
033 Knurled screw	034 Bearing housing
035 Cap head screw	036 Guide bearing
037 Knurled nut	037A Grub Screw
037B Bearing Shaft	038 Thrust bearing
039 Pilot shaft	040 Upper wheel
041 Bearing	042 Coach bolt
043 Brush	044 spacer
045 Flanged nut	046 Circlip
047 Idler wheel	048 Bearing
049 Sliding shaft	050 NVR switch
051 Cam	052 Tapped flange
053 End cap	054 Setting knob
055 Thin hex nut	056 Threaded rod
057 Blade tensioner bracket	058 Nut
059 Quick release shaft bearing	060 Quick release shaft
061 Thin nut	062 Locking handle
063 Thin nut	064 Cap
065 Setting knob	066 Hex head bolt
067 Hex head bolt	068 Washer
069 Wing nut	070 Hex head bolt
071 Washer	072 Turn lock fastener
073 Locking knob	074 Washer
075 Adjusting knob	076 n/a
077 Lower bearing bolt	078 Dust extraction outlet
079 Knurled thumbscrew	080 Guide pin housing
081 Motor pulley	082 Motor
083 Nut	084 Hand wheel
085 Shaft	086 Gearwheel
087 Locking handle	088 Spacer
089 Upper trunion	090 Lower trunnion
091 Pointer	092 Spacer

093 Screw	094 Coach bolt
095 Table	096 Table insert
097 Wing nut	098 End cap
099 Fence bracket	100 Coach bolt
101 Fence	102 Pressure plate
103 Fence carrier	104 Plastic pressure plate
105 Self tapping screw	106 Cam
107 Handle	108 Cap
109 Shaft	110 Pointer
111 Cap head bolt	112 Cover plate, right
113 Rip fence carrier	114 Wing bolt
115 Cover plate, left	116 Handle
117 Hand wheel	118 Setting collar
119 Belt tensioner shaft	120 Screw
121 Microswitch cover	122 Microswitch
123 Microswitch box	124 Nut
125 Lock washer	126 Self tapping screw
127 Blade guard	128 Tyre
129 Belt	130 Blade
131 Cap head bolt	132 Lower wheel
133 Spacer	134 Pulley
135 Spring washer	136 Hex nut
137 Spring washer	138 Fixing plate
139 Frame	140 Scale
141 Parallel pin	142 Table angle scale
143 Spring	144 Spacer
145 Push stick	145 Hook
146 Lock Insert	147 Lock Housing
148 Lock washer	149 Lock Nut
150 Lock Tongue	